

ADH.7... 4/3 AND 4/2 PILOTED VALVES CETOP 7/NG16



Type ADH.7 distributors are intended for interrupting, inserting and diverting a hydraulic system flow. Normally these distributors are composed of a main stage, crossed by the circuit main flow, and of a pilot stage available in several versions.

Various types of controls are available, used either individually or in combination for, among other functions, stroke limitation and main spool movement speed control, in order to optimize the hydraulic system operation where this type of valve is employed.

In those cases where normally to drain spools are used, it is necessary to remember that the minimum changeover pressure due to the opposing springs is equal to approximately 5 bar (see the operating features table next pages) and it is consequently necessary to specify when ordering the check valve incorporated in the P line, if required (as shown below).

- Mounting surface in accordance with UNI ISO 4401 - 07 - 06 - 0 - 94 standard (ex CETOP R 35 H 4.2-4-07).
- Pilot operated spool, solenoid controller.
- Stroke control of main spool.
- Presetting for pressure reducing valve mounting.
- Presetting for single-acting throttle valve mounting.

ADH.7...	
STANDARD SPOOLS FOR ADH.7	CH. I PAGE 53
TECH. SPECIFICATIONS ADH.7...	CH. I PAGE 54
SUBPLATES BSH.7...	CH. I PAGE 55/56
CETOP 3/NG06	CH. I PAGE 8
STANDARD SPOOLS FOR AD.3.E	CH. I PAGE 10
AD.3.E...	CH. I PAGE 11
ADC.3...	CH. I PAGE 5
"A09" DC COILS	CH. I PAGE 7
"D15" DC COILS	CH. I PAGE 18
"B14" AC SOLENOIDS	CH. I PAGE 18
STANDARD CONNECTORS	CH. I PAGE 19

ORDERING CODE

ADH	Piloted valve - Pilot valves and any modulating valves should be ordered separately
7	CETOP 7/NG16
*	Mounting type (see next page)
**	Spool type (see next page)
*	Piloting and draining I = X internal / Y internal IE = X internal / Y external EI = X external / Y internal E = X external / Y external (see Tab.1 at side)
R	Check valve incorporated at port P (Tab. 2) Only for I and IE versions (omit if not required)
**	00 = No variant LC = Main spool stroke limiter
2	Serial No.

TAB. 2 - INTERNAL CHECK ON P

ADH7*.*.*.R.**.2 VERSION

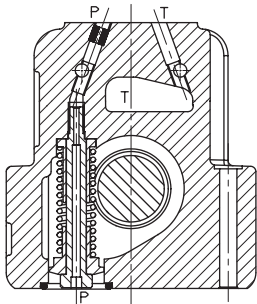

• For the spools 02-04-14-28 the piloting is normally external; the internal piloting is possible only with the internal check valve (R).

TAB. 1 - PLUGS ARRANGEMENT FOR THE PILOT AND DRAIN LINES

Plugs type used: M5x5 both for pilot and drain.

Note: standard M6x6 orifice Ø1,5 insert in the P port (Z)

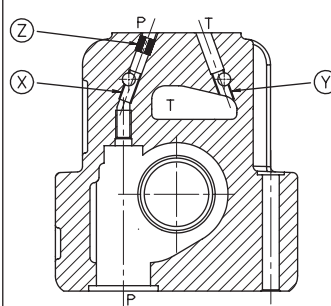

ADH.7...I

X internal piloting
Y internal draining

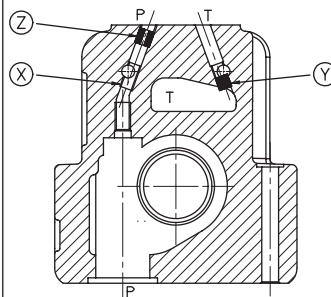
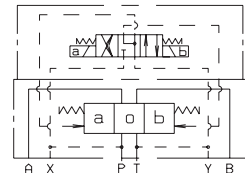

ADH.7...IE

X internal piloting
Y external draining

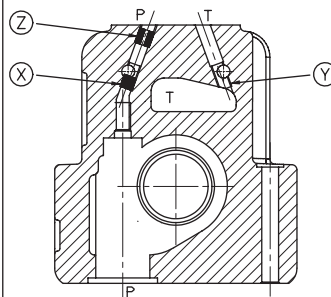
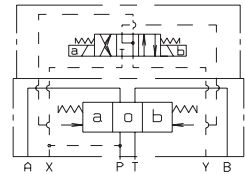

ADH.7...EI

X external piloting
Y internal draining

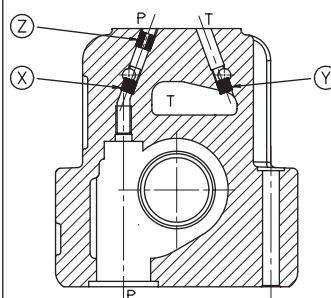
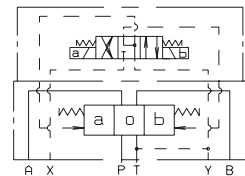

ADH.7...E

X external piloting
Y external draining

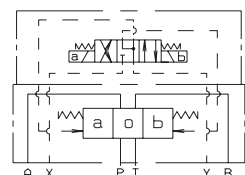

PRESSURE DROPS

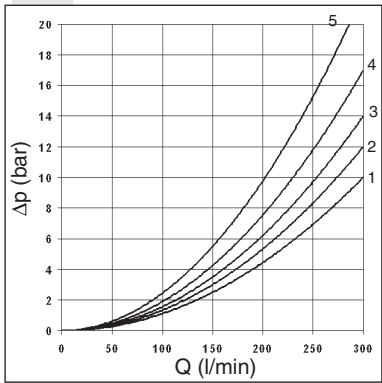

The two diagrams show the "Pressure drops" in relation to spools adopted for normal usage (see table). The fluid used was a mineral based oil with a viscosity of 46 mm²/s at 40° C.

PRESSURE DROPS FOR INTERNAL CHECK ON P VERSION

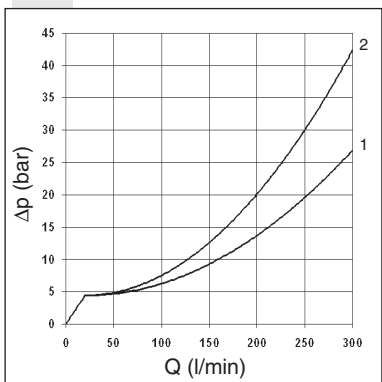

Spool type	Connections		
	P→A	P→B	P→T
02	1	1	1
04	1	1	2

Curve No.

The limit of use test has been carried out with external draining and orifice Ø1,5 insert in the P port (Z). The fluid used was a mineral based oil with a viscosity of 46 mm²/s at 40° C.

(*) For the "E mounting" the locating spring works only with the steady system (* Spools with price increasing)

Spool type	Connections					
		P→A	P→B	A→T	B→T	P→T
01	ENERGIZING DE-ENERGIZ.	2	1	3	3	
02	ENERGIZING DE-ENERGIZ.	1	1	3	3	2
03	ENERGIZING DE-ENERGIZ.	2	1	3	3	
04	ENERGIZING DE-ENERGIZ.	2	2	4	4	5
05	ENERGIZING DE-ENERGIZ.	1	1	2	2	
66	ENERGIZING DE-ENERGIZ.	1	1	2	3	4
10	ENERGIZING DE-ENERGIZ.	2	1	3	3	
14	ENERGIZING DE-ENERGIZ.	1	1	3	3	4
28	ENERGIZING DE-ENERGIZ.	1	1	3	3	4
23	ENERGIZING DE-ENERGIZ.	2	1	3	3	

Curve No.

LIMIT OF USE

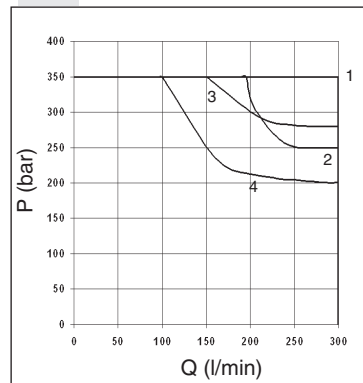

Spool type	No. Curve
01	1
02	2
03	1
04	3
05	1
66	1
10	1
14	4
28	4
23	1

SPOOLS AND MOUNTING TYPE

	C mounting	A mounting	B mounting	E mounting (*)	P mounting
Pilot Piloted	AD.3.E.03.C... ADH.7.C...	AD.3.E.03.E... ADH.7.A...	AD.3.E.03.F... ADH.7.B...	AD.3.E.16.E... ADH.7.E...	AD3E16E/AD3E16F ADH.7.P...
Scheme					
Spool type					
01					
02					
03					
04*					
05					
66					
10*					
14*					
28*					
23*					

PILOT SOLENOID CONTROL VALVE SPECIFICATIONS

FOR DIFFERENT CONTROLS, PLEASE CONTACT OUR TECHNICAL ARON SERVICE

1

Max. operating pressure ports P/A/B	350 bar
Max. operating pressure port T (int. drainage)	160 bar
Max. operating pressure port T (ext. drainage)	250 bar
Max. piloting pressure	210 bar
Min. piloting pressure	12 bar
Max flow	300 l/min.
Piloting oil volume for engagement 3 position valves	4 cm ³
Piloting oil volume for engagement 2 position valves	8 cm ³
Hydraulic fluid	mineral oil DIN 51524
Fluid viscosity	2.8 ÷ 380 mm ² /s
Fluid temperature	-20°C ÷ 70°C
Ambient temperature	-20°C ÷ 50°C
Max. contamination level	class 10 in accordance with NAS 1638 with filter $\beta_{25} \geq 75$
Weight ADH7 without pilot valve	7 Kg
Weight ADH7 with pilot valve with 1 AC solenoid	8,2 Kg
Weight ADH7 with pilot valve with 1 DC solenoid	8,4 Kg
Weight ADH7 with pilot valve with 2 AC solenoids	8,5 Kg
Weight ADH7 with pilot valve with 2 DC solenoids	9 Kg

Note: the solenoid valve type **ADC.3.E...** (with A09 coil) and **AD3.E...** (with D15 or B14 coils) could be used both as pilote valve, without any changement of technical features.

Switching time

Such values refer to a tests carried out with Aron solenoid valve type AD3E03 with P = 100 bar pressure and Q = 100 l/min flow. Orifice ϕ 1.5 mm, insert on piloting port, using a mineral oil at 40°C. with 46 mm²/s viscosity.

TEMPI DI RISPOSTA VALVOLA PILOTATA

Solenoids	ENERGIZING $\pm 10\%$ (ms)		DE-ENERGIZING $\pm 10\%$ (ms)	
	01 - 03		01 - 03	
No. Spool	01 - 03		01 - 03	
Scheme	2 positions	3 positions	2 positions	3 positions
AC	50	20	25	30
DC	70	35	40	50
Solenoids	02		02 - 04	
	04		02 - 04	
No. Spool	02	04	02 - 04	02 - 04
Scheme	2 posit.	2 posit.	3 posit.	2 positions
AC	35	60	30	25
DC	55	80	40	50

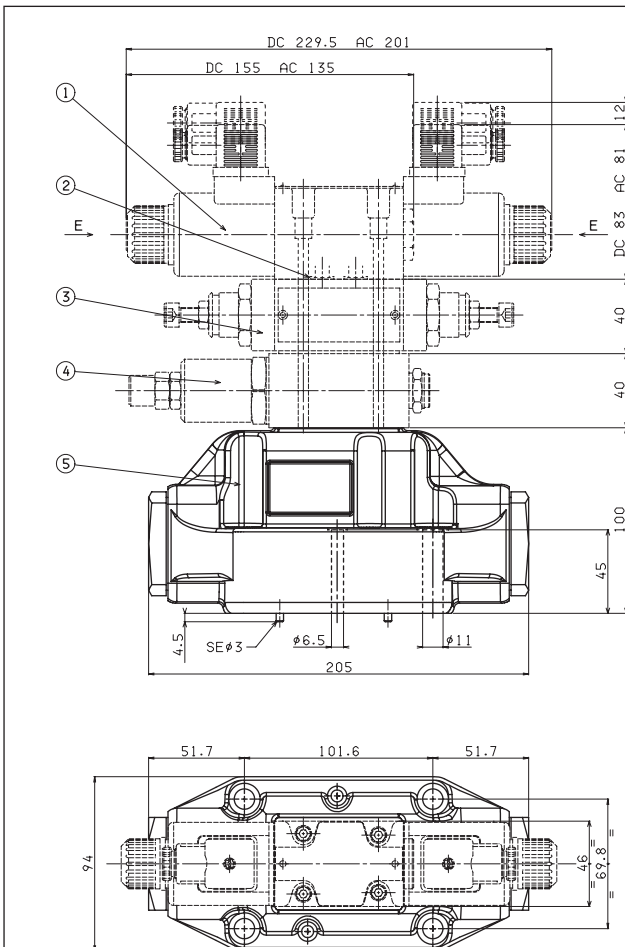

- 1 Piloted solenoid valve type **AD3E...** or **ADC.3.E...** CETOP 3/NG6
- 2 Calibrated diaphragms **AD3E...**
- 3 Flow regulation valve type **AM3QF..C**
- 4 Pressure reduction valve type **AM3RD..C**
- 5 Main valve type **ADH7..E**

CETOP 7 MOUNTING SURFACE

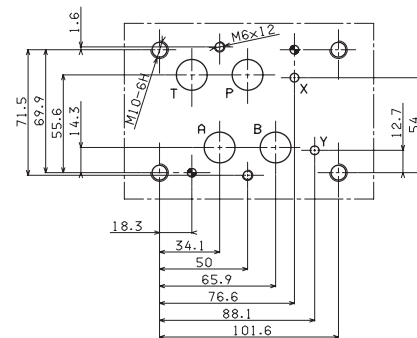

- Piloted valve fixing:
 - n° 4 screws T.C.E.I. M10x60 - Tightening torque 40 Nm
 - n° 2 screws T.C.E.I. M6x55 - Tightening torque 8 Nm
 - Fixing screws UNI 5931 with material specifications 12.9
- Seals:
 - n° 4 OR 2-118 PARKER (type 130)
 - n° 2 OR 2-013 PARKER (type 2043)

SPOOL STROKE ADJUSTMENT

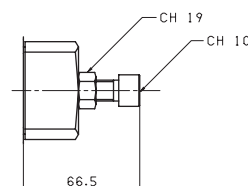

BSH.7.12 WITH P, T, AND A, B REAR 3/4" BSP

- BSH** Single plate for piloted valve
- 7** CETOP 7/NG16
- 12** 3/4" BSP rear connectors
- 00** No variant
- 1** Serial No.

Weight: 5,5 Kg
Fixing screws M8x55 UNI 5931

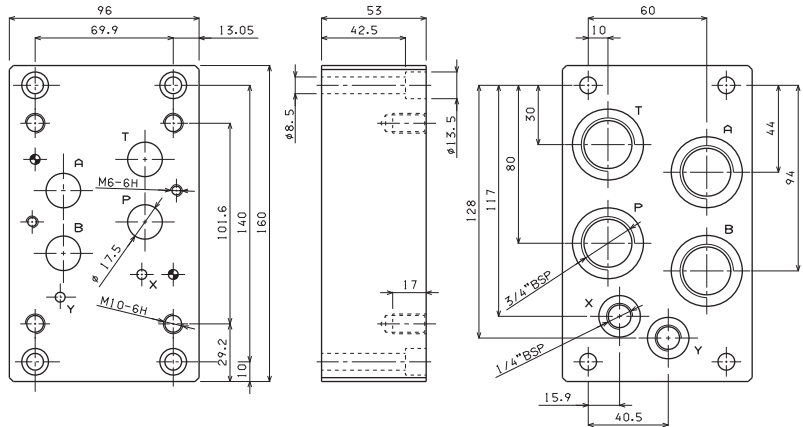

BSH.7.13 WITH P, T AND A,B REAR 1" BSP

- BSH** Single plate for piloted valve
- 7** CETOP 7/NG16
- 13** 1" BSP rear connectors
- 00** No variant
- 1** Serial No.

Weight: 4,7 Kg
Fixing screws M8x55 UNI 5931

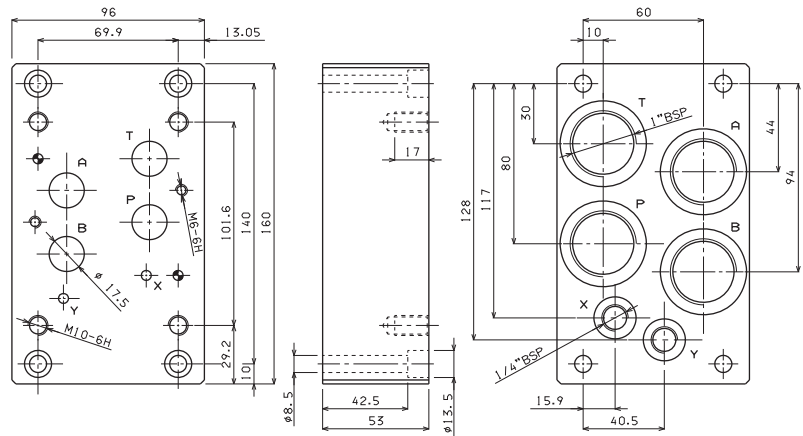

BSH.7.14 WITH P, T AND A, B SIDE 3/4" BSP

- BSH** Single plate for piloted valve
- 7** CETOP 7/NG16
- 14** 3/4" BSP side connectors
- 00** No variant
- 1** Serial No.

Weight: 6,3 Kg
Fixing screws M8x55 UNI 5931

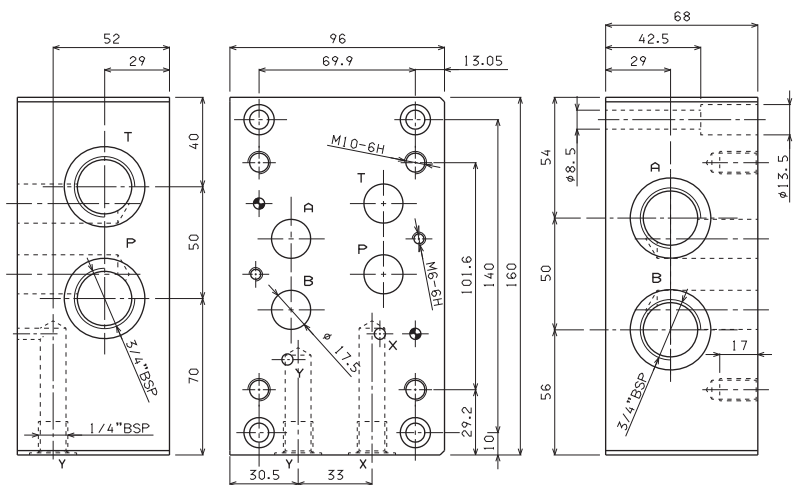

1

BSH.7.15 WITH P, T AND A, B SIDE 1" BSP

- BSH** Single plate for piloted valve
- 7** CETOP 7/NG16
- 15** 1" BSP side connectors
- 00** No variant
- 1** Serial No.

Weight: 6,3 Kg
Fixing screws M8x55 UNI 5931

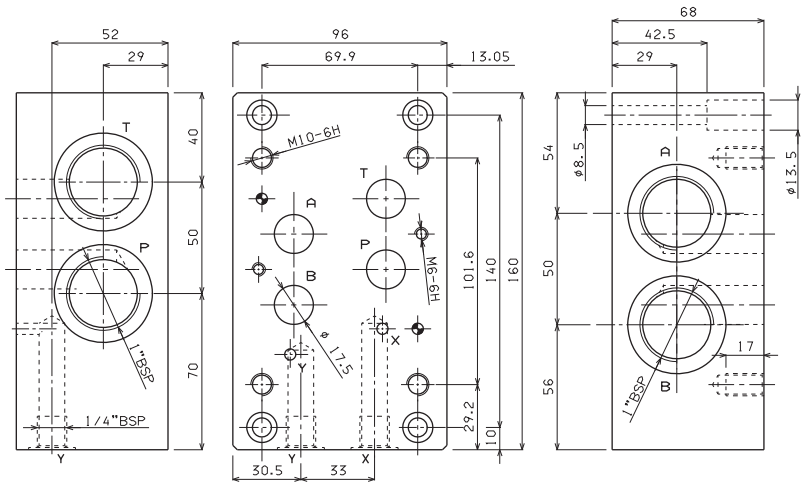

BSH.7.16 WITH P AND T REAR, A AND B SIDE 3/4" BSP, X AND Y REAR

- BSH** Single plate for piloted valve
- 7** CETOP 7/NG16
- 16** 3/4" BSP rear and side connectors
- 00** No variant
- 1** Serial No.

Weight: 5,1 Kg
Fixing screws M8x50 UNI 5931

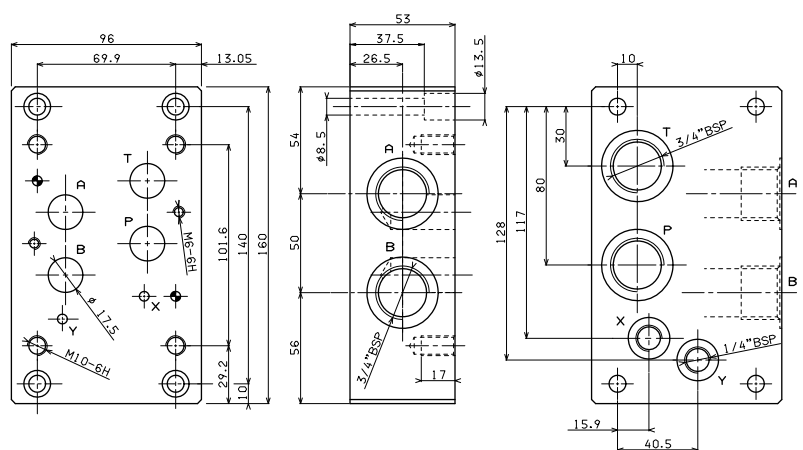

BSH.7.17 WITH P AND T REAR, A AND B SIDE 1" BSP, X AND Y REAR

- BSH** Single plate for piloted valve
- 7** CETOP 7/NG16
- 17** 1" BSP rear and side connectors
- 00** No variant
- 1** Serial No.

Weight: 5,3 Kg
Fixing screws M8x55 UNI 5931

